



**China 's LE World 's LE**  
**Innovation to realize dream, together with LE**  
**Vending machine manufacturer**

# Contents

Sincerely thank you for the purchase of our vending machines.  
Before you start to operate the machine, please read this manual carefully.  
Use the machine correctly after a good understanding.Or, an accident or danger may occur by misoperation.Please keep this manual properly and don't lose it.

We will not make any notice if we update the machine or modify the manual, which will be known by different versions of the manual in future. Of course, please allow some differences between the real machine and the manual. If you find any difference that is not clear in manual book, please inform us immediately. Because if you start to use the machine without informing us the difference, we will not be responsible for any damage caused by the difference.

All rights reserved: no copying of the whole or part of the manual is permitted until the written consent of the author has been obtained.

The machine meets the following:

GB/T 4706.1-2005 "safety of household and similar electrical appliances: first parts: General requirements" ; GB4706.19-2008 "safety of household and similar electrical appliances - special requirements for liquid heaters"

Requirements for environmental conditions for the operation of Hangzhou Yile Vending Machines:

1. Ambient temperature: the upper limit is 38℃, the lower limit is 4℃ (indoor).
2. Ambient humidity: not higher than 90%RH (relative humidity).
3. Altitude: 1000m below.
4. The place without chemical corrosion and violent vibration
5. non open space (no direct sunlight, rain, wind sand, etc.)
6. It is only suitable for temperate climate
- 7 or other places that are not allowed by other laws and regulations

Statement: all the consequences, which have not been followed by our company's environmental requirements, are unrelated to Hangzhou Yile.

The products (machines and accessories) delivered to you are manufactured according to the laws and standards implemented by the relevant countries and regions, so they cannot be exported, trafficked or transferred to other countries of destination with different laws and standards.

<b>Chapter 1 Precautions.....</b>	<b>03</b>
<b>Chapter 2 Introduction of the machine.....</b>	<b>05</b>
<b>Chapter 3 Pre-use preparation .....</b>	<b>07</b>
<b>Chapter 4 Start and operation.....</b>	<b>08</b>
<b>Chapter 5 Background system usage.....</b>	<b>16</b>
<b>Chapter 6 Daily maintenance of the coffee machine.....</b>	<b>17</b>
<b>Chapter 7 Boiler 's dirty treatment.....</b>	<b>19</b>
<b>Chapter 8 Common fault and elimination method.....</b>	<b>20</b>
<b>Chapter 9 Warrantee guarantee notice.....</b>	<b>21</b>











# Chapter 1 Precautions

Before you use the machine, please read the manual carefully. The safety precautions shown here are important for safety. Please follow them.

## ※ Warnings and notices







<b>Warnings</b>	When used incorrectly, there is a possibility of death or injury.
<b>Notices</b>	When used incorrectly, there is a possibility of injury or material damage.





## ※ Security identity

	Mustn't		Disassembly
	Mustn't		No touch
	Must be observed		Must be grounded
	Pay attention		Pay attention to electric shock
			High temperature
			Watch your hand
			Pay attention to fire













## ※ After reading this instruction, please keep it properly

### Warnings

	Please ask Professional and technical personnel for installation and movement. Improper installation may result in dumping, electric shock, fire or burn.
	Professional disassembly only. Unauthorized disassembly may cause an accident.
	Must be grounded. It is necessary to use independent dedicated socket and reliable grounding. The earth resistance should be less than 4Ω.
	No climbing, No swaying, No tilting. May lead to dumping.
	Do not operate the switch with a wet hand. There is a risk of electric shock.
	Do not pull or use a broken power cord. There may be fire or electric shock.
	Unplug the plug immediately when there is an abnormality. Remove the power plug and contact the professional maintenance personnel or manufacturer when there is abnormal smell, smoke or fire, otherwise it may cause electric shock or fire.

	Forbidden to place in children's game places. There is a potential for injury.
	Electrical parts splashed or immersed in water are prohibited from use without treatment. remove the water and dust, and confirm that after the insulation is restored, it will be used by professional maintenance personnel.
	Do not touch the moving parts with your hands. There is a possibility of injury.
	Do not use flammable goods near the vending machine. There is a risk of explosion or fire.
	Do not place items at the top of the machine. The possibility of leakage of electricity caused by the fall or the overflow of water.

### Notices

	Please discuss with the professional and technical personnel when placed in the following places. • Sites exposed to sea breeze or corrosive gas. • Places with rocking or vibrant.
	Please discuss with the relevant departments when setting up the following places. • Places that may hinder traffic. • Places near road sign or a signal lamp. • Places near Fire fighting equipment. • Road and facilities for asylum. • Places with combustible or flammable gases.
	The power capacity shall be in conformity with the equipment. It may cause a fire if the power supply does not match or the power capacity is small.
	The power cord cannot be tied into bundles. It may cause fire or electric shock after heating.
	Keep the power cord away from the heating appliance. It may cause fire or electric shock.
	Do not touch the internal parts of the machine during the operation of the equipment. There is a possibility of burns or electric shock.
	Daily hygiene management in accordance with food hygiene requirements. There is a risk of accidents , If no health management.
	Check the leakage protector regularly once a year. There is a risk of electric shock if no leakage switch.
	check the tightness of the fixed metal parts regularly 6 months. There is a possibility of an accident.
	Check the power plug regularly once a year. Dust or poorly connected power plug may cause electric shock or fire.
	When the equipment is not used for a long time, please unplug the power plug and take out the water inside the machine. It may cause breakage of boiler and electric shock If the water inside the machine is not drained.
	It is indoor machine, Please use the machine under 4 to 38 degrees Celsius. It is possible to cause equipment failure.

## Chapter 2 About the machine

All parts as bellow

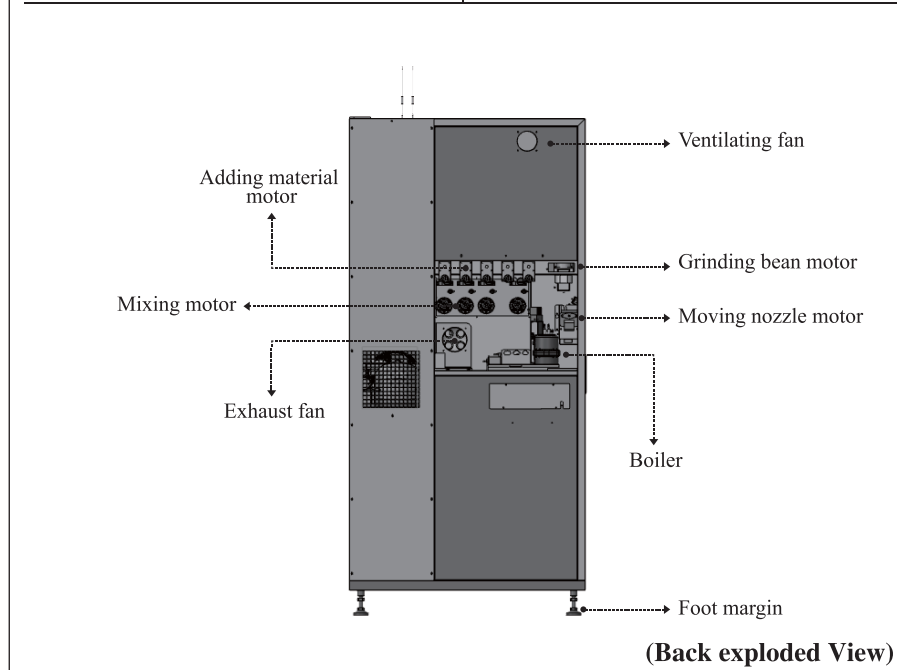
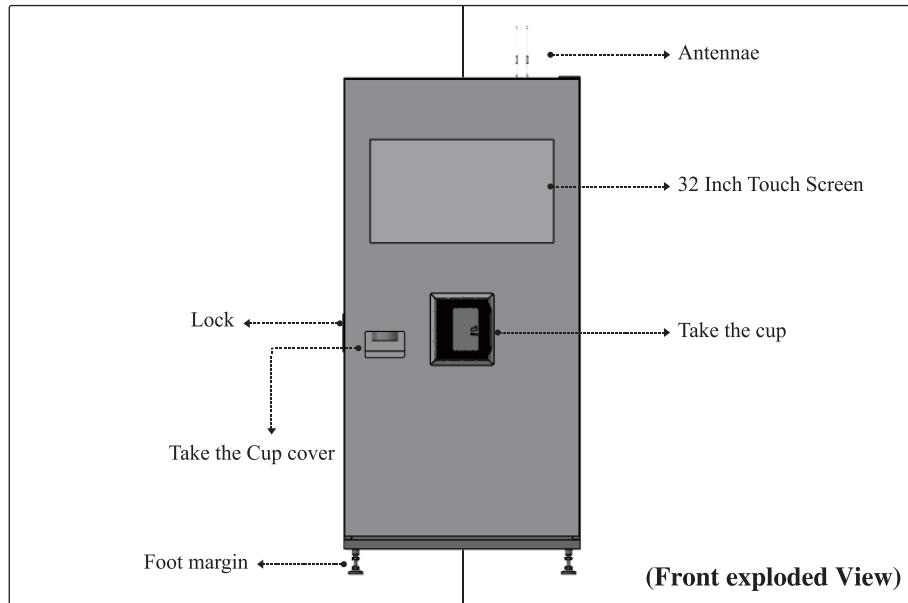

05

## About the machine

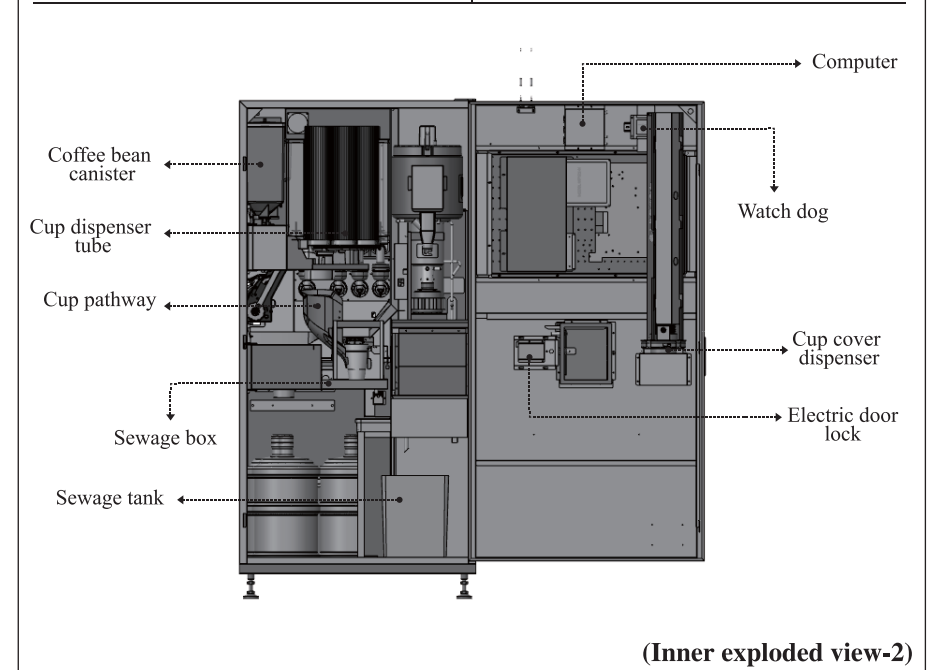
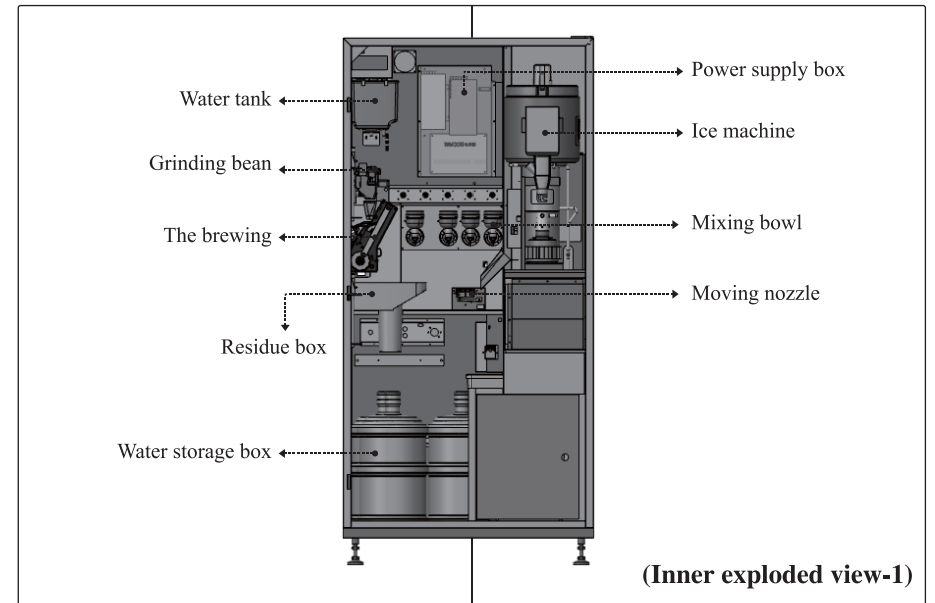

06

## Chapter 3 Preparation for pre-using

### 1. Remove all packaging components:

The machine is packed in wooden case, so you need remove a foam base, adhesive tape and fixed accessories. Torn off the thin clothing if back or side body covered, please be careful because of electrostatic. Please count the random accessories and materials; check the goods according to the content of packing list, contact the supplier if anything deficient.

### 2. Place for laying the machine

Laying requirement: Please lay this machine aside a well ventilated place, keep 10cm space for including body around the back, good for heat dissipation.

Environment requirement: The indoor temperature should be between 4~38 C.

Network requirement: Have a stable 3G signal or WIFI coverage.

Power supply: The capacity of the power supply should be greater than 1700W ( the rated power of the machine), using independent specialized socket and reliable grounding.

### 3. Preparation before starting the machine

Please read the manual carefully before you start the machine. Put the pure water in the machine and insert the water pump into the bucket.

### 4. Fill the coffee bean and powders

About the ordering of raw materials, see the chart below please.

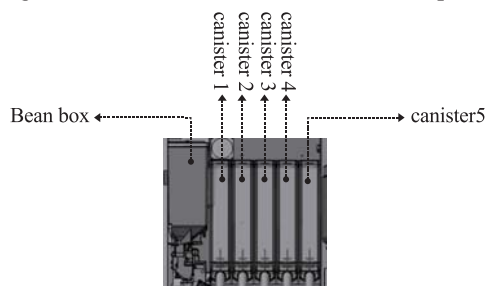

( 1 ) Canister 1-5. Look at the picture below, take the canister apart ,and then add the instant powder as the drink ratio.

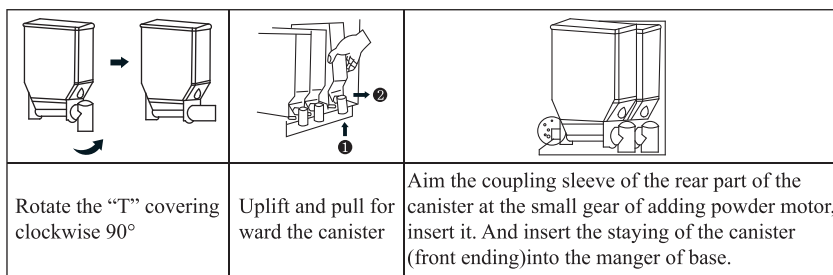

( 2 ) Take out coffee bean box and fill coffee bean (when picking up the coffee bean box, Please push the bottom block into the box.

## Chapter 4 Start and operation

Insert the power plug into the three-wire grounded socket, open the machine compartment door, push the power switch up, and the equipment starts. It takes about 40S to start the device, and it will automatically detect during the start up process. After the start up is completed, the machine door will open, the screen will automatically jump to the local management terminal, enter and exhaust, and the new machine must be exhausted after the first power-on operating.

### Notice:

- 1、 The internal packaging needs to be removed before starting the machine, and the water supply to the equipment is sufficient.
- 2、 Exhaust test to the water outlet, water can flow smoothly, usually 2-3 times.

### 1. Entering the function operation menu

Machine serial number

Warning: Each machine has a unique device number which is the password. please don't set or change any password without factory's suggestion

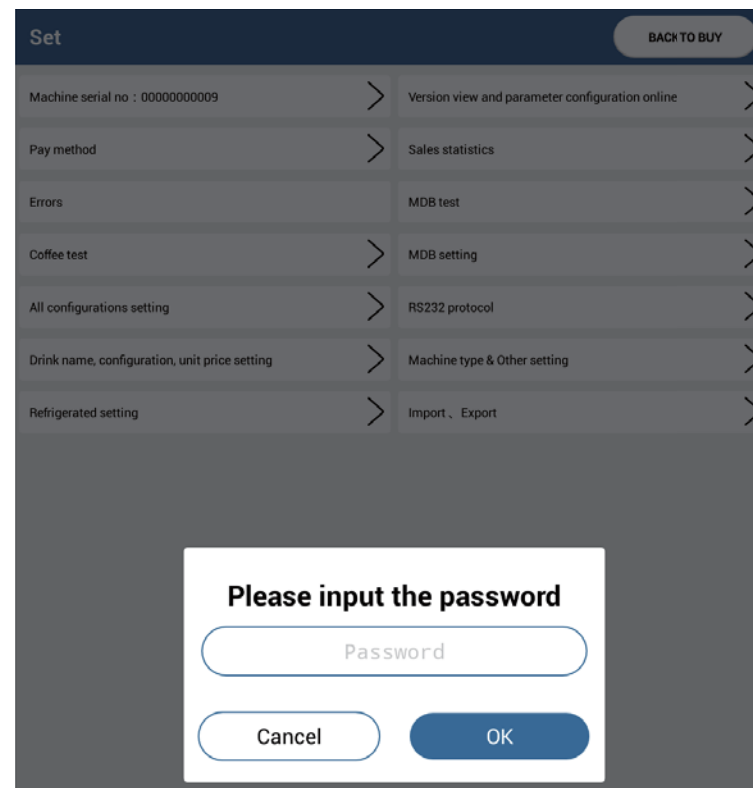

## 2. Payment method

The machine supports WeChat, Alipay, cash (including coins and notes), third-party payment methods, you can choose the payment method according to your needs.

Pay method	Checked	Configuration
Cash	<input checked="" type="checkbox"/>	
Alipay	<input checked="" type="checkbox"/>	
Wechat	<input checked="" type="checkbox"/>	
Third party (1) (Need to be customized)	<input checked="" type="checkbox"/>	
Third party (2) (Need to be customized)	<input checked="" type="checkbox"/>	CONFIGURATION SAME
Third party (3) (Need to be customized)	<input checked="" type="checkbox"/>	CONFIGURATION SAME
Third party (4) (Need to be customized)	<input checked="" type="checkbox"/>	CONFIGURATION SAME

## 3. Drink testing

Individual parts of the machine can be individually tested to quickly find and solve problems. The functions set by this machine include door lock opening, door lock closing, cup dispenser, cover dispenser, grinding bean motor, brewing motor, and brewing. Motor under, water pump, exhaust, external transfer, built-in nozzle, powder electromagnet, cleaning brewer, cleaning, etc.

Current water temperature : °C  
Highest water temperature : °C  
Lowest water temperature : °C  
The remaining water volume : ml  
Error code :  
Current action :  
Results :  
Have cups or not :  
Current configuration :  
Refresh time :

**Action results**  
2018-11-07 13:56:33.055 The communication status of the machine : true

## 4. Setting of common parameter and powder canister

- 1、 Set drinks temperature  
You can set the brewing temperature of the beverage. The factory setting minimum temperature is 85 °C, the highest temperature at 95 °C, click the save and return button at the top right of the screen after setting.
- 2、 Setting of powder canister  
The machine with 5 canisters, to facilitate drink configuration and raw material addition, raw material placed in each channel should be changed accordingly. Click the save and return button at the top right of the screen after setting.
- 3、 Set sugar  
Set no sugar/ 1/3 sugar/ 1/2 sugar/ 1 sugar accordingly.

**All configurations setting** SAVE & BACK

**All configurations setting**

Temperature(75-105)      Lowest  85       Highest  100

Auto cleaning      Times of out ice currently: 0 RESET      Times of making drinks(1-50)  10

**Powder canisters setting**      Powder Canister number : 5      Sugar canister : 5      RESET

Canister 1      Name :

Canister 2      Name :

Canister 3      Name :

Canister 4      Name :

Canister 5      Name : Sugar (Can not modify)

Sugar configuration	Water volume (ml) (10-400)	Powder time (s) (1-12)	Mixing time (s) (0-10)
Low sugar	<input type="button" value="−"/> 20 <input type="button" value="+"/>	<input type="button" value="−"/> 1.0 <input type="button" value="+"/>	<input type="button" value="−"/> 0.0 <input type="button" value="+"/>
Half sugar	<input type="button" value="−"/> 20 <input type="button" value="+"/>	<input type="button" value="−"/> 2.0 <input type="button" value="+"/>	<input type="button" value="−"/> 0.0 <input type="button" value="+"/>
High sugar	<input type="button" value="−"/> 20 <input type="button" value="+"/>	<input type="button" value="−"/> 3.0 <input type="button" value="+"/>	<input type="button" value="−"/> 0.0 <input type="button" value="+"/>

Consumer choice

## 5. Coffee name, formula, price setting

As following picture you can set coffee name, formula and price, click save and return button at the top right of the screen after setting.

**Drink name, configuration, unit price setting** SAVE & BACK

UNIT PRICE OF ALL DRINKS IS 0.01

Drink1 Name:  Refrigerate Hot drinks Sugar Half sugar Price:  >

Drink2 Name:  Refrigerate Hot drinks Sugar Half sugar Price:  >

Drink3 Name:  Refrigerate Hot drinks Sugar Half sugar Price:  >

Drink4 Name:  Refrigerate Hot drinks Sugar Half sugar Price:  >

Drink5 Name:  Refrigerate Hot drinks Sugar No sugar Price:  >

Drink6 Name:  Refrigerate Ordinary te. Sugar Half sugar Price:  >

Drink7 Name:  Refrigerate Ordinary te. Sugar Half sugar Price:  >

Drink8 Name:  Refrigerate Ordinary te. Sugar No sugar Price:  >

Drink9 Name:  Refrigerate Hot drinks Sugar No sugar Price:  >

**Mocha Cocoa Drink configuration** SAVE & BACK

ALL VALUE WILL BE MINIMUM

Order	Drink configuration	Water volume (ml) (10-400)	Powder time (s) (1-12)	Mixing time (s) (0-10)
<input checked="" type="checkbox"/> order1	Grinding Bean (Coffee bean)	<input type="button" value="−"/> 20 <input type="button" value="+"/>		
<input checked="" type="checkbox"/> order2	Powder Canister 2 (Cocoa Pow..)	<input type="button" value="−"/> 90 <input type="button" value="+"/>	<input type="button" value="−"/> 1.5 <input type="button" value="+"/>	<input type="button" value="−"/> 0.0 <input type="button" value="+"/>
<input checked="" type="checkbox"/> order3	Grinding Bean (Coffee bean)	<input type="button" value="−"/> 20 <input type="button" value="+"/>		
<input checked="" type="checkbox"/> order4	Powder Canister 1 (Powdered..)	<input type="button" value="−"/> 30 <input type="button" value="+"/>	<input type="button" value="−"/> 1.0 <input type="button" value="+"/>	<input type="button" value="−"/> 0.0 <input type="button" value="+"/>

**Refrigerated setting** SAVE & BACK

Refrigerate way

Choose ice maker      Less ice      Making ice for 0.5 sec      Normal ice      Making ice for 0.5 sec      Extra ice      Making ice for 0.5 sec

Ice making ways

## 6. Checking the version and online parameter configuration

You can view the native program version and the latest server version of the server as following picture.

**Version view and parameter configuration online** BACK

The machine is drive version :

The machine is software version : 1.0.3

The server latest software version : 1.0.2

## 7. Sales data statistics

Enter the sales data statistics interface as following picture, you can check total sales volume, amount and real-time transactions situation. Sales data will be saved for only recently 3 months, others will be cleared each restart.



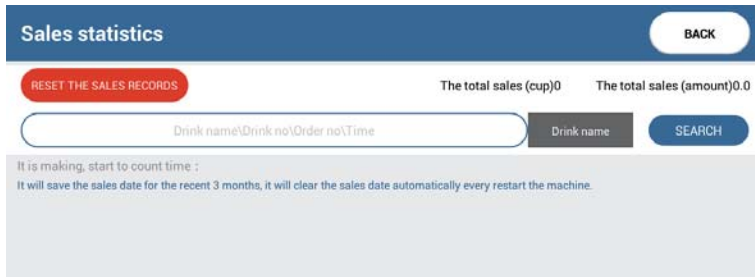

## 8. MDB testing

Working status of the coin and bills can be tested separately. Please pay attention to the opening operation before using each function.

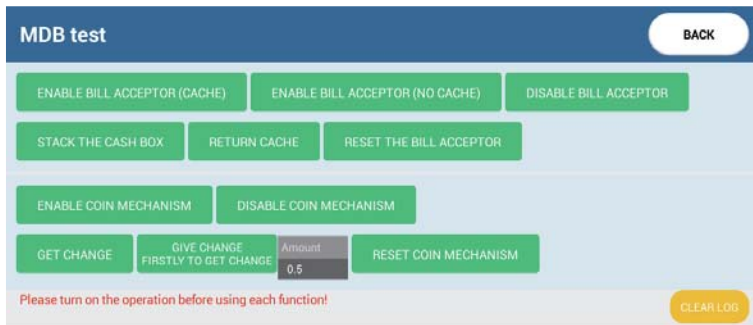

## 9. Serial port configuration

This machine with 3 serial port configurations: coffee serial port, ice maker serial port, MDB serial port. Serial port of the machine is set by default generally, don't set it yourself. If you need to set it, please contact the manufacturer for consultation.

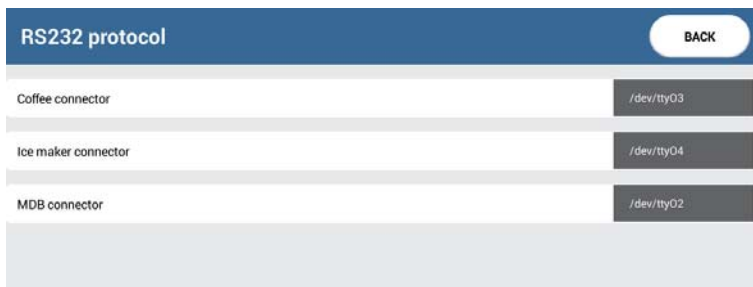

## 10. Other setting

There are electric door configuration, infrared configuration, cup dispenser configuration, free mode, save log, currency abbreviation, currency symbol, language (Chinese and English) configuration with or without, or you can restore the factory settings, save and return buttons at the top right of the screen after setting.

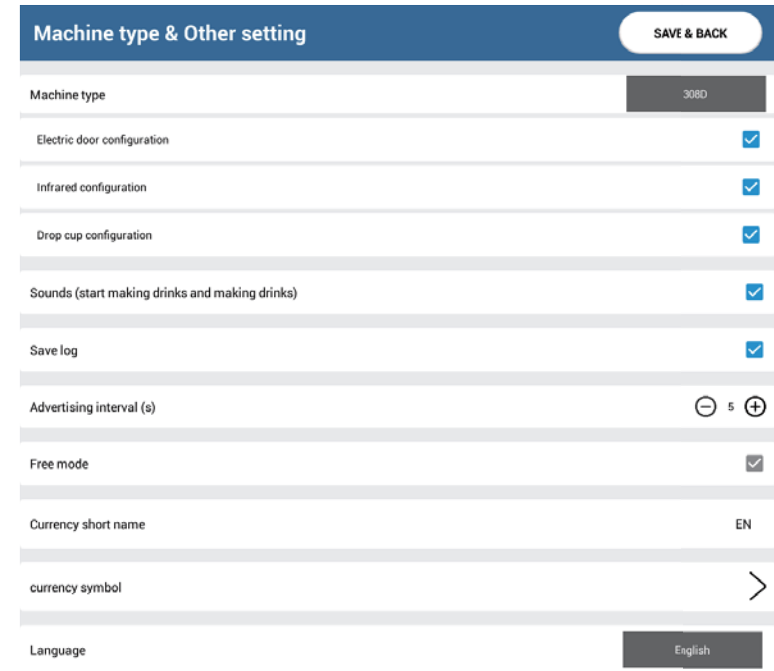

## 11. Import and export data

You can import and export configuration and videos/ images from U disk.



**Import , Export** BACK

**EXPORT THE CONFIGURATION**

Export the coffee configurations of the software to the file of vm/config of U disk.

**IMPORT THE CONFIGURATION**

Import the coffee configurations of the file of vm/config of U disk to the software.

**IMPORT THE VIDEOS AND PICTURES**

- Build a folder in U disk: vm.
- Drinks pictures: place them under the file of vm/goodsimg in the U disk; firstly build a folder goodsimg under the vm folder, and then put the drink pictures into the goodsimg file.
  - named coffee1.png, coffee2.png... coffee16.png, up to 16; the recommended size is 400\*400px.
- Drinks detailed pictures: Place it under the file of vm/goodsinfo in the U disk; firstly build a folder goodsinfo under the vm folder, and then put the drinks detailed pictures under the goodsinfo file.
  - named coffee1.png, coffee2.png... coffee16.png, up to 16; the recommended size is 400\*400px.
- The advertising pictures and videos: Place it under the file of vm/salesres in the U disk; firstly build a folder salesres under the vm folder, then put the advertising pictures and videos under the salesres file.
  - The advertising pictures: named s1.png, s2.png ... No quantity requirement. The recommended size is 1000\*590px.
  - The advertising videos: s1.mp4, currently supporting only one video, and the recommended aspect ratio is 100:59.
- Background pictures: Place it under the vm/vmres file in the U disk; firstly build a folder vmres under the vm folder, and then put the background pictures under the vmres file.
  - Background pictures: named salebg.png, the recommended size is 1920\*1080px.
- Third-party payment icon: Place it under the vm/apkkey file in the U disk; firstly build a folder apkkey under the vm folder, and then put the third-party payment icon under the apkkey file.
  - Third-party payment icon: named threepay1.png... threepay4.png, up to 4; the recommended size is 200\*200px.
- If failure to import, the vm file of the U disk can be copied directly (the file has been operated according to the above steps) to the sdcard file of the industrial computer.

## 12. Mode button enters the background setting interface

Press the MODE button to set the parameters of the whole machine.



**Set** BACK TO BUY

Machine serial no : 0000000009	>	Version view and parameter configuration online	>
Pay method	>	Sales statistics	>
Errors	>	MDB test	>
Coffee test	>	MDB setting	>
All configurations setting	>	RS232 protocol	>
Drink name, configuration, unit price setting	>	Machine type & Other setting	>
Refrigerated setting	>	Import , Export	>

## Chapter 5 Background system usage

Vending machine backstage is a system used to manage vending machine operation, sale, replenishment management and other functions. The background login account is the mailbox number. The login address, account number and password (initial 000000) will be sent to the registered mailbox automatically. Login address: <http://115.29.179.158/vmmis/login.jsp> enter the account number, password and verificationcode to enter user management system, as shown in Figure 5-9.

Serial number	Equipment ID	Device type	Last connection time	Container	Network type	Signal strength	Equipment state	Device error message	Driver version	Computer version of the machine	Barcode status	Coin state
1	0000000001	Integrated machine	2019-04-21 10:06:30		WiFi	-84	normal	OK	-1	vmmis_v1.0.0	normal	normal
2	0000000001	Integrated machine	2019-04-21 08:13:41		LTE	-61	normal	OK	-1	vmmis_v1.0.0	normal	normal
3	1701000001	Integrated machine	2019-04-21 10:06:30		WiFi	-84	normal	OK	-1	vmmis_v1.0.0		
4	1701000002	Integrated machine	2019-04-20 08:43:07		WiFi	0	normal	OK	-1	vmmis_v1.0.0		
5	1701000003	Integrated machine	2019-04-21 10:29:41		WiFi	-71	normal	OK	-1	vmmis_v1.0.1	normal	normal
6	1701000004	Coffee machine					normal				redaction	redaction
7	0000000002	Coffee machine	2019-05-26 10:25:58		NETWORK_WIFI	-1	normal	HWISS002	vm_300C_v1.0_20171219	coffee_v1.0.1	normal	normal
8	0000000003	Coffee machine	2019-05-24 12:19:33		-1	-77	normal	-1	-1	vmmis_v1.0.0	redaction	redaction
9	0000000004	Integrated machine					normal				redaction	redaction

(5-9)

As shown above, after entering the management system, the upper left corner is the basic information of the current user. The top blue menu bar is all the functional menu, and can pull down to view the submenu, as follows:

- Basic data: user list, operation and point provider list, upper computer list, change of upper computer, delete upper computer / migration data, line list, commodity name (integrated machine), goods name (adult machine), beverage name (drink machine).
- VM real time data: integrated machine / adult machine, drink machine, coffee machine, integrated machine / adult machine setting information, coffee machine setting information, coffee machine setting information, integrated machine / adult machine inventory, drink machine inventory, coffee D formula, VM sales record, non cash payment record.
- VM auxiliary functions: track (integrated machine / adult machine), material channel (drink machine), location of VM, modification of track price (integrated machine), revision of track number (comprehensive machine), and generating supplement.
- Data statistics report: historical sales data, based on name or date.
- User settings: user parameters and password modification.

**Background specific operation please see "Hangzhou Le vending machine backstage operation manual".**

## Chapter 6 Daily maintenance of the coffee machine

Carry out routine hygiene management according to food hygiene requirements and carry out regular cleaning and maintenance.

### 1. Cleanliness

Please unplug the power plug before cleaning. It is better to use warm water for cleaning.

#### (1) Inside the machine



① The material box: take the raw material box down, remove the raw material, soak in the water with the sponge to clean, use the electric hair dryer to dry the rear, then assemble it in situ, otherwise it may cause the material powder to solidify because of the wet gas. It is suggested that the machine be cleaned monthly.

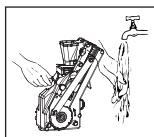

② The blower: after the discharge is unloaded, clean it directly with tap water, and the electric hair dryer is used to dry the rear. otherwise it may cause the material powder to solidify because of the wet gas. It is suggested that the machine be cleaned monthly.

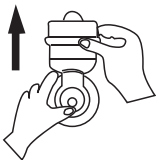
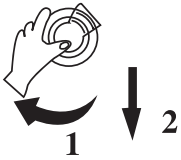

③ Mixing system: lift the mixing cap out, pull the mixing bowl forward and pull out after it is rotated, then pull the mixing bucket down clockwise, and soak the disassembled mixing system in water and use a soft sponge to scrub. otherwise it may cause the material powder to solidify because of the wet gas. It is suggested that the machine be cleaned daily.

		
Lift up the mixing cap and pull the bowl forward, then turn left and pull out.	Pull the stirring bucket out of the clockwise and pull out.	Soak the removed mixing system in water and scrub with soft sponge.

④ beans cabinet: remove the beans cabinet, pour out the coffee beans and clean them up in clean water. After drying with a hair dryer, put the coffee beans in place, 1-2 times cleaning a month is suggested. Clean the machine interior: wipe out the powder leaking out of the machine with the brush and wipe it with a wet cloth.

#### (2) The outside of the machine

① Waste water box: pull out the waste water box, drain the accumulated water, and immerse it in the clear water. Wash the face and put it back in place. It is recommended to wash it once a day.

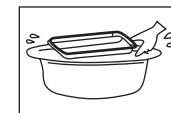

② Waste residue box: pull out the left hand side of the machine, remove the waste box and drain the waste residue. And clean it, wipe it clean and put it back in place. It is recommended to wash it once a day.

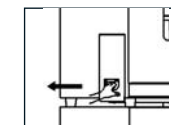

③ Machine shell: wipe the machine shell with a wet towel. It is recommended to wash it once a day.

### 2. check

#### Leakage protector

- ① After pressing the test button, if the handle is in the <OFF> position, it is normal.
- ② 3 minutes after confirming the action, push the handle to the <ON> position.

## Chapter 7 Boiler 's dirty treatment

### 1. Purpose

Cleaning the dirty of the boiler and improving the health standard of drinking water.

### 2. Content

Due to the recent reflection from customers that the boiler is in use for a period of time and a large amount of calcium carbonate and other precipitates will appear inside the boiler. It has seriously affected the health standard of the drinking water of the coffee machine. Therefore, it is aimed at the boiler's dirty , a large number of analysis and decontamination tests have been carried out.

Due to the heating reaction between Calcium and magnesium ion, it will form calcium carbonate and magnesium hydroxide and to form the dirty after precipitation , which has an adverse effect on the health of the human body. And if the boiler is not cleaned for a long time, dirt will be deposited on the inner wall, bottom and heating pipes of the boiler. Therefore, after the boiler is used for a period of time, the dirty removal must be carried out regularly to prevent a large amount of calcium carbonate and other precipitates inside the boiler.

### 3. Processing treatment

After repeated tests, finally, we confirm the solution to remove the dirty of the boiler:

1. to take 1.5 liters of warm water, then add 80g (about 1/3) citric acid descaling agent, stirring and dissolving.
2. to put the pump in the solvent, exhaust in the boiler heating state, exhaust 3~4 times repeatedly, or until the pump is not pumped the water, then stop the exhaust and wait for 15 minutes.
3. to put the pump back into the pure water tank, drain the tank water, then carry out the 5~7 exhaust, and wash the boiler and water tank. The dirty treatment of the post boiler can be completed.

### 4. Matters of attention

1. To clean the boiler dirt at least 1 times a month!
2. It is recommended that the company store some boiler descaling agents for customers to purchase and use, and customers can also purchase food grade detergent.
3. In the test, the best effect is to use the heart brand food grade citric acid descaling agent.



## Chapter 8 Common fault and elimination method

Fault	Possible cause	Elimination method
Non electricity	1. The power plug is not plugged in.	1. Confirm that the power line is plugged in.
	2. Leakage protector tripping.	2. It is confirmed that the leakage protector is on.
Flow Meter Fault	1. flow meter is blocked or damaged.	1. Change the flow meter.
Water shortage	1. Water tank water shortage.	1. Check the water in the bucket.
Pump overtime	1. Damage of lower pump.	1. Check whether the pump is normal.
Malfunction of grinding bean motor	1. The coffee beans are used up or the barn block is not opened.	1. See if there is a bean or whether the barn block is open.
	2. Grinding motor blocked.	2. Test again after change thicker powders.
	3. The line is not connected well.	3. Check whether the line is loose or unconnected.
Temperature sensor failure	1. Temperature sensor damage.	1. Check to see if the temperature is normal. 0 degrees indicates that the temperature sensor line is defective or damaged.
NTC fault	1. Overheat protector protection.	1. Check whether the overheat protector is on.
	2. A problem with the grinding drive plate.	2. Check whether there is electricity at both ends of the heating pipe.
Too little water out of coffee	1. Outlet obstruction.	1. Clean out the outlet.
	2. Bubble block.	1. Cleaning bubble.
Brew motor abnormality	1. Damage of the brew motor.	1. Check the motion of the brew motor.
	2. The line of the brew motor is not connected well.	2. Check whether there is electricity at both ends of the brew motor
	3. A problem with the grinding drive plate.	
Run overtime of the brew motor	1. The problem of the induction switch of the brew motor.	1. Check whether the induction switch is abnormal.
	2. There is a problem with the drive board.	2. Confirm whether the drive board is normal.
Communication failure	1. The serial port line is not connected.	1. Check whether the serial line is connected correctly.

## Chapter 9 Warrantee guarantee notice

### 1. Warranty card

Please keep this warranty carefully, no reissue if lost.  
Please keep this commercial bill and valid purchasing proof(need manufacturer stamped). Show them when machine fault and send depot service. If you can not offer these proof, then the product warranty period of the date will be the corresponding product serial number of the ex factory date.

### 2. Guarantee clause

Since the products sold date, in normal conditions using and a hardware failure occurs, We offer free guarantee repair for 1 year.

#### We would have the right to charge for repairing with under situations

- 1) Accident, Nature disaster like fire, flood, lightening, unauthorized modification;
- 2) Non-authorized person repairing or dissembling;
- 3) The damage caused by after sale transportation;
- 4) Do not according o the instructions on the provisions, free installation, display, or using the non-specified voltage, using the non-earthing power socket;
- 5) The damage caused by not using substitute or alternative parts meet the our company standard;
- 6) Normal wear;
- 7) Other reasons that no relation with product quality.
- 8) Please return the receipt of the warranty card from the purchasing day in 15 working days.
- 9) This warranty is applicable only to mainland China.

Hangzhou Yile Shangyun Robot Technology Co., Ltd. keep the right of final explanations.

### 3. Specifications

Dimension	Height:1900 x Width:900 x Depth:783mm
Net weight	≈255kgs/pc
Power Specification	AC220V/50Hz or AC110V/60Hz
Rated output	2000W
Beverage type	16 Kinds of hot drinks (with ice available)
Water supplying	Pump
Cup storage & size	About 280pcs of 14 o.z. paper cups
Payment system	Cashless payment available, or free mode
Environmental conditions	Highest temperature:38℃,Lowest temperature:2℃(Indoor)



## Warranty Card

Machine Model		<b>The supplier's stamp</b>	
Serial No			
Name of supplier			
The time machine			
Customer Name		Phone No	
Customer Address		Postal Code	

No.	Repair time	Fault conditions	Replace Parts.	Repair man	Customer's signature
1					
2					
3					
4					
5					
6					
7					
8					
9					
10					

Remarks: